



State of New Jersey

DEPARTMENT OF ENVIRONMENTAL PROTECTION

Bureau of Nonpoint Pollution Control

Division of Water Quality

Mail Code 401-02B

Post Office Box 420

Trenton, New Jersey 08625-0420

609-633-7021 Fax: 609-777-0432

http://www.state.nj.us/dep/dwq/bnpc_home.htm

CHRIS CHRISTIE

Governor

KIM GUADAGNO

Lt. Governor

BOB MARTIN

Commissioner

January 11, 2017

David Scott, CPSWQ
General Manager
Hydro International
94 Hutchins Drive
Portland, ME 04102

Re: MTD Laboratory Certification
Up-Flo[®] Filter by Hydro International
Off-line Installation

TSS Removal Rate 80%

Dear Mr. Scott:

The Stormwater Management rules under N.J.A.C. 7:8-5.5(b) and 5.7(c) allow the use of manufactured treatment devices (MTDs) for compliance with the design and performance standards at N.J.A.C. 7:8-5 if the pollutant removal rates have been verified by the New Jersey Corporation for Advanced Technology (NJCAT) and have been certified by the New Jersey Department of Environmental Protection (NJDEP). Hydro International has requested a Laboratory Certification for the Up-Flo[®] Filter System.

This project falls under the "Procedure for Obtaining Verification of a Stormwater Manufactured Treatment Device from New Jersey Corporation for Advanced Technology" dated January 25, 2013. The applicable protocol is the "New Jersey Department of Environmental Protection Laboratory Protocol to Assess Total Suspended Solids Removal by a Filtration Manufactured Treatment Device" dated January 25, 2013.

NJCAT verification documents submitted to the NJDEP indicate that the requirements of the aforementioned protocol have been met or exceeded. The NJCAT letter also included a recommended certification TSS removal rate and the required maintenance plan. The NJCAT Verification Report with the Verification Appendix for this device is published online at <http://www.njcat.org/verification-process/technology-verification-database.html>.

The NJDEP certifies the use of the Up-Flo[®] Filter by Hydro International at a TSS removal rate of 80%, when designed, operated and maintained in accordance with the information provided in the Verification Appendix and subject to the following conditions:

1. The maximum treatment flow rate (MTFR) for the manufactured treatment device (MTD) is calculated using the New Jersey Water Quality Design Storm (1.25 inches in 2 hrs) in N.J.A.C. 7:8-5.5. The MTFR is calculated based on a verified loading rate of 1.264 gpm/sf of effective filtration treatment area.
2. The Up-Flo[®] Filter shall be installed using the same configuration as the unit verified by NJCAT, and sized in accordance with the criteria specified in item 6 below.
3. This device cannot be used in series with another MTD or a media filter (such as a sand filter), to achieve an enhanced removal rate for total suspended solids (TSS) removal under N.J.A.C. 7:8-5.5.
4. Additional design criteria for MTDs can be found in Chapter 9.6 of the New Jersey Stormwater Best Management Practices (NJ Stormwater BMP) Manual which can be found on-line at www.njstormwater.org.
5. The maintenance plan for a site using this device shall incorporate, at a minimum, the maintenance requirements for the Up-Flo[®] Filter, which is attached to this document. However, it is recommended to review the maintenance website at http://www.hydro-int.com/sites/default/files/nj_uff_inspection_and_maintenance.pdf for any changes to the maintenance requirements.
6. Sizing Requirements:

The example below demonstrates the sizing procedure for an Up-Flo[®] Filter.

Example: A 0.25-acre impervious site is to be treated to 80% TSS removal using an Up-Flo[®] Filter. The impervious site runoff (Q) based on the New Jersey Water Quality Design Storm was determined to be 0.79 cfs or 354.58 gpm.

The selection of configuration for use in the Up-Flo[®] Filter is based upon both the MTFR and the maximum inflow drainage area. It is necessary to select the configuration using both methods and to rely on the method that results in the larger configuration determined by the two methods.

Inflow Drainage Area Evaluation:

The drainage area to the Up-Flo[®] Filter in this example is 0.25 acres. Based upon the information in Table 1 below, the following minimum configuration is required in an Up-Flo[®] Filter to treat the impervious area without exceeding the maximum drainage area:

Model Size UFF-ZV-19-285R with MTFR of 285 gpm and Maximum Allowable Inflow Drainage Area of 0.264 acre

Maximum Treatment Flow Rate (MTFR) Evaluation:

The site runoff (Q) was determined based on the following:

time of concentration = 10 minutes

i=3.2 in/hr (page 5-8, Fig. 5-3 of the NJ Stormwater BMP Manual)

c=0.99 (runoff coefficient for impervious)

$Q=ciA=0.99 \times 3.2 \times 0.25 = 0.79$ cfs = 0.79×448.83 gpm = 354.58 gpm

Based on a flow rate of 354.58 gpm, the following minimum configurations are required in an Up-Flo[®] Filter System to treat the impervious area without exceeding the MTFR:

Model Size UFF-ZV-38-285R with MTFR of 570 gpm and Maximum Allowable Inflow Drainage Area of 0.528 acre

The MTFR Evaluation results will be used since that method results in the higher minimum configuration determined by the two methods.

The sizing table corresponding to the available system models are noted below:

Table 1 Up-Flo[®] Filter Configurations and NJDEP Sizing Table

Configuration	Model Size	Number of Filter Modules	Max. Filtration Rate ¹ (gpm)	Minimum Sedimentation Area ^{1,2} (sq.ft.)	Minimum Wet Volume ^{1,2} (cu.ft.)	Total Filtration Area ¹ (sq.ft.)	Total Mass Capture ¹ (lbs)	Maximum Allowable Inflow Area ¹ (Acres)
Manhole	UFF-MH-285R	6	90	12.57	31.30	71.22	50.0	0.083
Vault	UFF-ZV-19-285R	19	285	39.79	99.12	225.5	158	0.264
Vault	UFF-ZV-38-285R	38	570	79.59	198.2	451.1	317	0.528
Vault	UF-ZV-57-285R	57	855	119.4	297.4	676.6	475	0.792

¹ Refer to Table A-1 of NJCAT Verification Report dated December 2016: UFF Design Specifications for the design parameters

² The precast structure housing the filter modules shall have at least the "Min. Sedimentation Area"

Be advised a detailed maintenance plan is mandatory for any project with a Stormwater BMP subject to the Stormwater Management Rules, N.J.A.C. 7:8. The plan must include all of the items identified in Stormwater Management Rules, N.J.A.C. 7:8-5.8. Such items include, but are not limited to, the list of indication of problems in the system, and training of maintenance personnel. Additional information can be found in Chapter 8: Maintenance and Retrofit of Stormwater Management Measures.

If you have any questions regarding the above information, please contact Shashi Nayak of my office at (609) 633-7021.

Sincerely,

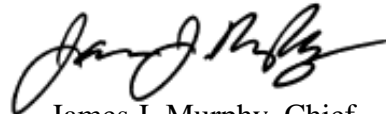
A handwritten signature in black ink, appearing to read "James J. Murphy". The signature is fluid and cursive, with the first name "James" being the most prominent.

James J. Murphy, Chief
Bureau of Nonpoint Pollution Control

Attachment: Maintenance Plan

cc: Chron File
Richard Magee, NJCAT
Vince Mazzei, NJDEP - DLUR
Ravi Patraju, NJDEP - BES
Gabriel Mahon, NJDEP - BNPC
Shashi Nayak, NJDEP – BNPC



Operation and Maintenance Manual

Up-Flo® Filter

Filtration System for Stormwater Treatment

Stormwater Solutions

94 Hutchins Drive
Portland, ME 04102

Tel: (207) 756-6200
Fax: (207) 756-6212
stormwaterinquiry@hydro-int.com

www.hydro-int.com



Overview & Product Description

DON'T WANT TO GO IT ALONE? CALL HYDRO AND WE'LL TAKE CARE OF INSPECTION, REPLACEMENT MEDIA AND CLEANOUT.

CALL 1 (888) 382-7808 FOR A QUOTE

The Up-Flo® Filter is a modular high-rate stormwater filtration device designed to capture trash, oil, sediment and remove fine pollutants such as dissolved and particulate metals and nutrients from stormwater runoff. In general, a minimum of two inspections are required per year to monitor sediment and gross pollutant accumulations.

In order to sustain expected flow and removal rates for the Up-Flo® Filter, annual replacement of the Media Pack and removal of accumulated sediment from the sump is required. Depending on site use and pollutant characteristics, annual rainfall, design and functionality of the stormdrain conveyance system, annual replacement and clean out may be more or less often.

The Up-Flo Filter has modular components that connect together to form a ring of 1-6 Filter Modules or linearly to fit into rectangular precast structures with filter bays. Each filter bay can house 1-19 Filter Modules and precast structures can be constructed with multiple filter bays. Each Filter Module will have either a filtration Media Pack or filtration Ribbons.

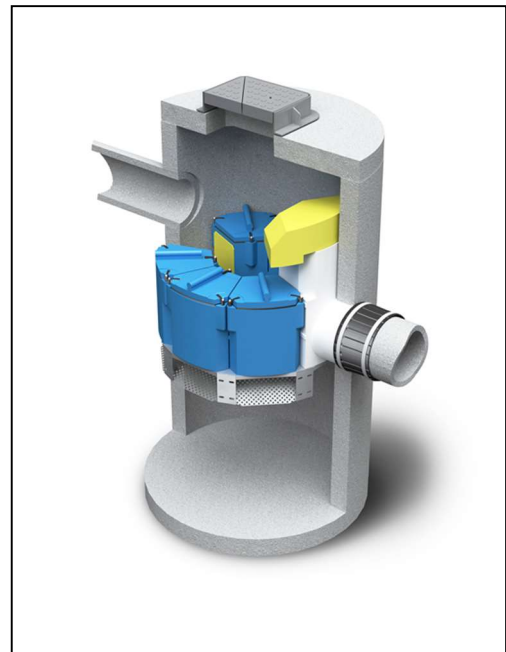
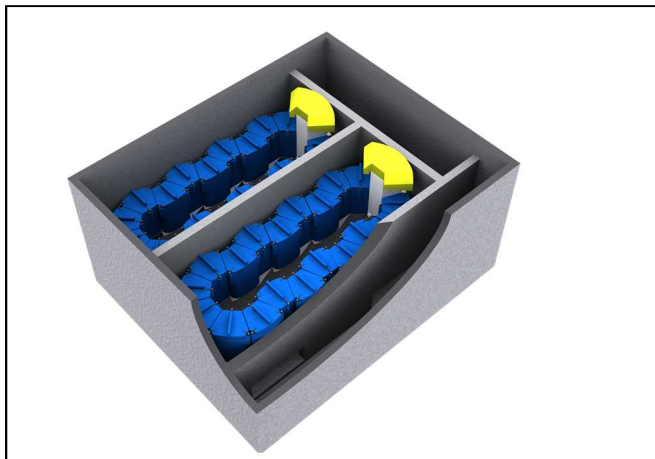



It does not matter what type of media is used, the Filter Modules house the filtration medium and the precast structure is used to suspend the Filter Modules to provide a sedimentation sump. Stainless steel support frames are used to support the Filter Modules and attach them to the precast structure. An Outlet Module (with hood) is used to connect the Filter Modules to a discharge pipe and convey filtered water away from the treatment area. A Draindown Filter and screen are provided when filtration media is used but not with filtration Ribbons.

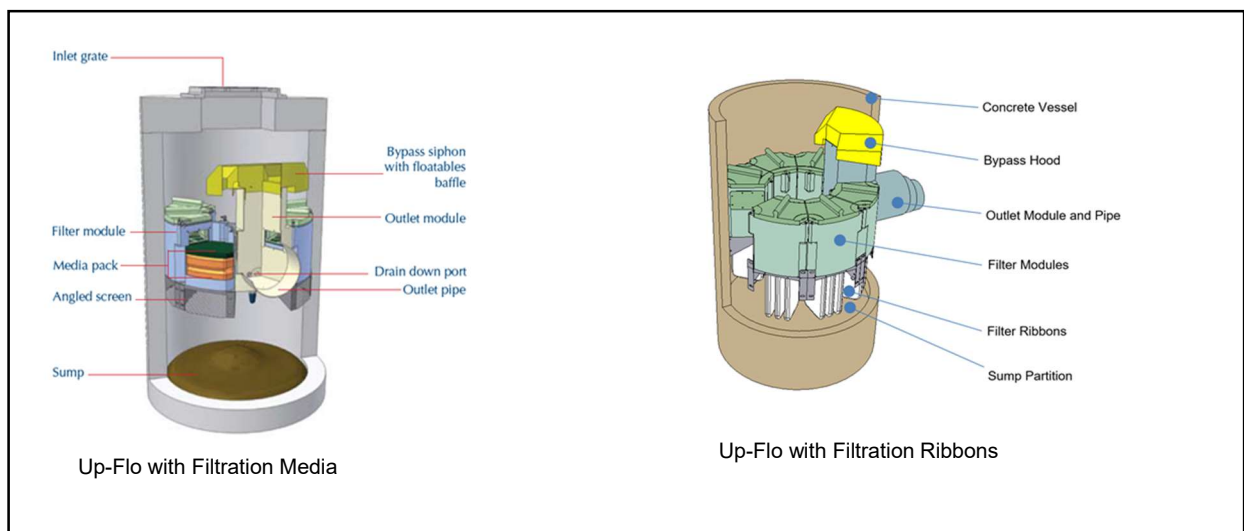

Maintenance activities can be categorized by those that can be performed from outside the Up-Flo® vessel and those that are performed inside the vessel. Maintenance performed from outside the vessel includes removal of floatables and oils that have accumulated on the water surface and removal of sediment from the sump. Maintenance performed inside the vessel includes removal and replacement of Media Packs (Filter Bags, flow Distribution Media and Draindown) or filtration Ribbons. A vactor truck is required for removal of oils, water, sediment, and to enter the vessel for performing inside maintenance. OSHA Confined Space Entry procedures need to be followed when entering the Up-Flo® vessel.

Inspection

The frequency of inspection and maintenance can be determined in the field after installation. Based on site characteristics such as contributing area, types of surfaces (e.g., paved and/or landscaped), site activities (e.g., short-term or long-term parking), and site maintenance (e.g., sanding and sweeping), inspection and maintenance should be conducted at intervals of no more than six months during the first year of operation. Typically, maintenance is recommended once per year thereafter.



By removing the manhole cover during a storm and monitoring the water level in the manhole or vault, site personnel can determine whether the filter is in bypass. A properly-sized filter that is in bypass during a storm that is producing runoff at, or below, the filter's design filtration rate needs maintenance. Otherwise, scheduled inspections will determine when one or more of the following maintenance thresholds have been reached:

- Sediment depth at sump storage capacity. Minimum 8" should separate the Draindown filter inlet from stored sediment in the sump or 6" should separate the bottom of the filtration Ribbons and sump floor. A simple probe, such as the Sludge-Judge®, can be used to determine the depth of the solids in the sump.
- Clogging of the Media Bags. Minimum filtration rate is generally reached when the Media Bags have accumulated approximately 20 lbs of sediment or when filtration Ribbons from one module have accumulated approximately 8 lbs. Determining the amount of accumulated sediment will be accomplished by removing both of the Media Bags from one of the Media Packs and weighing the bags separately or removing the filter Ribbon assembly as weighing. A spent Media Bag weighs approximately 50 lbs wet and a filter Ribbon assembly from one module weighs approximately 15 lbs spent .
- Draindown filter clogged. With modules supplied with filtration media, the Drain Down Filter is designed to lower the water level in the Up-Flo® vessel to an elevation below the bottom of the Filter Modules between storm events. If inspection one to two days after a storm event indicates otherwise, the Drain Down Filter has likely become clogged with sediment.
- Slime and debris covering the flow distribution media, angled screens or filtration Ribbons. After removal of the Media Bags or filtration Ribbons, the bottom flow distribution media should be removed and inspected to determine if it is coated with slime or debris. Similarly, the angled screen should be inspected for blockages and ragging.
- Oil forming a measureable thickness on the surface of the water. Since water in the Up-Flo® vessel drains down to an elevation below the bottom of the Filter Modules when the system is idle, the amount of accumulated oils must be minimized so that oils are not entrained into the Media Pack when stormwater begins to fill the vessel at the start of a storm event.
- Floatables completely covering the surface of the water. Similar to oils, the amount of accumulated floatables must be minimized to prevent trash and loose debris from becoming trapped on the angled screens when stormwater begins to fill the Up-Flo® vessel at the start of a storm event.



The site-specific solids loading rate in the sump and in the Media Packs will be determined during the first year of Up-Flo® Filter operation. Starting with a clean sump, the solids loading rate in the sump will be calculated by measuring the sediment depth in the sump and dividing the depth by the correlating interval of time since it was cleaned. Similarly, starting with fresh Media Bags or Ribbons, the solids loading rate in the Media Packs and Ribbons will be calculated by weighing the Media Bags or Ribbons and dividing the weights by the respective time interval since they were installed. The wet weight of the heaviest bag or Ribbon assembly from a single module will be used to determine the loading rate.

After completion of the first year of operation, the inspection and maintenance intervals for cleaning the sump and replacing Media Bags or Ribbons will be established to keep the solids loading within the respective limits of the sump and filter medium. Replacement of the Draindown Filter, replacement of flow Distribution Media, and removal of oils and floatables will occur at the same frequency unless the first year of operation indicates otherwise. Keeping to the established maintenance intervals will keep treatment flow rates at, or above, the design flow rate.

Maintenance

The access port located at the top of the manhole or vault provides access to the Up-Flo® vessel for maintenance personnel to enter the vessel and comfortably remove and replace Media Packs or Ribbon assemblies. The same access would be used for maintenance personnel working from the surface to net or skim debris and floatables or to vacuum out sediment, oil, and water. Unless the Up-Flo® Filter has been installed in a very shallow unit, it is necessary to have personnel with OSHA-confined space entry performing the maintenance that occurs inside the vessel.

Maintenance activities include inspection, floatables removal, oil removal, sediment removal, Media Pack and Ribbon assembly replacement, and Draindown Filter replacement. Filtration medium housed in the Filter Modules is easily accessed by loosening three latches used to secure the Filter Module Lid. Maintenance intervals are determined from monitoring the Up-Flo® Filter during its first year of operation. Depending on the site, some maintenance activities may have to be performed on a more frequent basis than others. In the case of floatables removal, a vacuum truck is not required. Otherwise, a vacuum truck is normally required for oil removal, removal of sediment from the sump, and to dewater the vessel for replacement of the Media Packs and Draindown Filter. All inspection and maintenance activities would be recorded in an Inspection and Maintenance Log.

Good housekeeping practices upstream of the Up-Flo® Filter can significantly extend Media Bag life. For example, sweeping paved surfaces, collecting leaves and grass trimmings, and protecting bare ground from the elements will reduce loading to the system. Media Packs should not be installed in the Filter Modules until construction activities are complete and site stabilization is effective.



Up-Flo Filter Inspection & Maintenance Logs

SITE REFERENCE NAME OR NUMBER FOR THIS UP-FLO® FILTER LOCATION:	
SITE NAME:	
SITE LOCATION:	
OWNER:	SITE CONTRACTOR:
CONTACT NAME:	CONTACT NAME:
COMPANY NAME:	COMPANY NAME:
ADDRESS:	ADDRESS:
TELEPHONE:	TELEPHONE:
FAX:	FAX:

INSTALLATION DATE: / /

CONFIGURATION (CIRCLE ONE): MANHOLE VAULT SYSTEM

TOTAL NUMBER OF UP-FLO® FILTER MODULES: _____



UP-FLO® FILTER INSPECTION LOG

Site Name: _____ Owner Change since last inspection? Y N

Location: _____

Owner Name: _____

Address: _____ Phone Number: _____

Site Status: _____

Date: _____ Time: _____ Site conditions*: _____

**(Stable, Under Construction, Needing Maintenance, etc.)*

Inspection Frequency Key: A=annual; M=monthly; S=after major storms

Inspection Items	Inspection Frequency	Inspected? (Yes/No)	Maintenance Needed? (Yes/No)	Comments/Description
Debris Removal				
Adjacent area free of debris?	M			
Inlets and Outlets free of debris?	M			
Facility (internally) free of debris?	M			
Vegetation				
Surrounding area fully stabilized? (no evidence of eroding material into Up-Flo® Filter)	A			
Grass mowed?	M			
Water retention where required				
Water holding chamber(s) at normal pool?	A			
Evidence of erosion?	A			
Sediment Deposition				
Filtration Chamber free of sediments?	A			
Sedimentation sump not more than 50% full?	A			
Structural Components				
Any evidence of structural deterioration?	A			
Grates in good condition?	A			
Spalling or cracking of structural parts?	A			
Outlet/Overflow Spillway	A			
Other				
Noticeable odors?	A			
Any evidence of filter(s) clogging?	M			
Evidence of flow bypassing facility?	A			



Inspector Comments: _____

Overall Condition of Up-Flo® Filter**: Acceptable Unacceptable

**"Acceptable" would mean properly functioning; "unacceptable" would mean damaged or required further maintenance.

If any of the above Inspection Items are checked "Yes" for "Maintenance Needed", list Maintenance actions and their completion dates below or on the Maintenance Log provided on page 15 of the Up-Flo® Filter Operation & Maintenance Manual:

Maintenance Action Needed	Due Date

The next routine inspection is schedule for approximately: (date) _____

Inspected by: (signature) _____

Inspected by: (printed) _____



UP-FLO® FILTER MAINTENANCE LOG

Site Name: _____ Owner Change since last inspection? Y N

Location: _____

Owner Name: _____

Address: _____ Phone Number: _____

Site Status: _____

Date: _____ Time: _____ Site conditions: _____
(Stable, Under Construction, Needing Maintenance, etc.)

Estimated volume of oil/floatable trash removed: _____

Sediment depth measured in sump prior to removal: _____

Number of Filter Modules fitted with new media packs: _____

Inspector Comments: _____

Overall Condition of Up-Flo® Filter: Acceptable Unacceptable

****"Acceptable" would mean properly functioning; "unacceptable" would mean damaged or required further maintenance.**

Maintained by: (signature) _____

Maintained by: (printed) _____

DO IT RIGHT THE FIRST TIME

LEARN MORE AT HYDRO-INT.COM/SERVICE



CALL 1 (888) 382-7808 TO SCHEDULE AN INSPECTION

Stormwater Solutions

94 Hutchins Drive
Portland, ME 04102

Tel: (207) 756-6200

Fax: (207) 756-6212

stormwaterinquiry@hydro-int.com

www.hydro-int.com

Turning Water Around...®