



# State of New Jersey

DEPARTMENT OF ENVIRONMENTAL PROTECTION  
Bureau of Nonpoint Pollution Control  
Division of Water Quality  
Post Office Box 029  
Trenton, New Jersey 08625-029  
609-633-7021 Fax: 609-984-2147  
[http://www.state.nj.us/dep/dwq/bnpc\\_home.htm](http://www.state.nj.us/dep/dwq/bnpc_home.htm)

JON S. CORZINE  
Governor

MARK N. MAURIELLO  
Acting Commissioner

December 9, 2009

John MacKinnon  
Hydro International  
94 Hutchins Drive  
Portland, ME 04102

Re: Conditional Interim Certification for the Up-Flo Filter with HydroFilter Sand  
by Hydro International

**Expiration Date: May 15, 2011**  
**TSS Removal Rate: 80%**

Dear Mr. MacKinnon:

The Stormwater Management rules under N.J.A.C. 7:8-5.5(b) and 5.7(c) allow the use of manufactured treatment devices (MTDs) for compliance with the design and performance standards at N.J.A.C. 7:8-5 if the pollutant removal rates have been verified by New Jersey Corporation for Advanced Technology (NJCAT) and have been certified by the New Jersey Department of Environmental Protection (NJDEP).

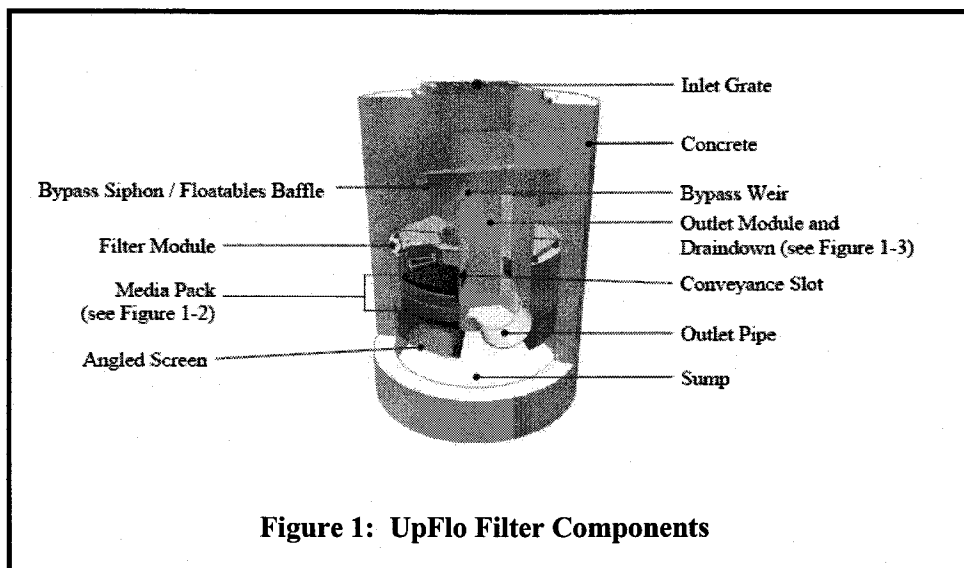

**Figure 1: UpFlo Filter Components**

The certification process has been revised. The revised process places MTDs into five categories. The UpFlo Filter by Hydro International qualified for Category III, MTDs with NJCAT Verification issued as of May 15, 2009.

The flowpath in the Up-Flo Filter is first toward the bottom of the chamber then up through the filter modules to the outlet. As the water rises in the chamber, the head differential forces water through filter media contained within the modules. A conveyance channel and slot located above the filters directs water to the outlet.

A head differential between the system inlet and outlet of thirty-one (31) inches will produce 0.045 cfs of flow (See Figures 1, 2, and 3.) A draindown mechanism allows the water to drain below the elevation of the filter media between storm events.

The NJDEP received the submitted data demonstrating the above approved TSS Removal Rate, a maintenance plan required under Category III, and a signed statement indicating that the maintenance portions of the 2009 NJDEP Testing Protocols as amended and supplemented (Hydrodynamic, Filter, or Field requirements in accordance with NJ Amendments of TARP) are incorporated into the maintenance plan.

Based on the NJCAT verification and the Department's review, the Department acknowledges that the requirements for this category are met; therefore, grants interim certification with an expiration date of May 15, 2011. The NJDEP certifies the use of the Up-Flo Filter with HydroFilter Sand by Hydro International at a TSS removal rate of 80%, subject to the following conditions:

1. The UpFlo Filter must be designed according to the NJ Water Quality Design Storm in N.J.A.C. 7:8-5.5.
2. The peak inflow of the water quality design storm is limited to 0.045 cfs per filter module. The maximum inflow area per filter module is limited to 0.3 acres of impervious area.
3. In the event that the elevation between storm events does not drop below the elevation of the filter media within thirty-six(36) hours, the draindown must be replaced.
4. The UpFlo Filter is certified as an off-line system only. Any flow above the New Jersey water quality design storm must be bypassed around the system.
5. The UpFlo Filter must provide a minimum 2.8 cf of sediment storage volume for each filter module. If the

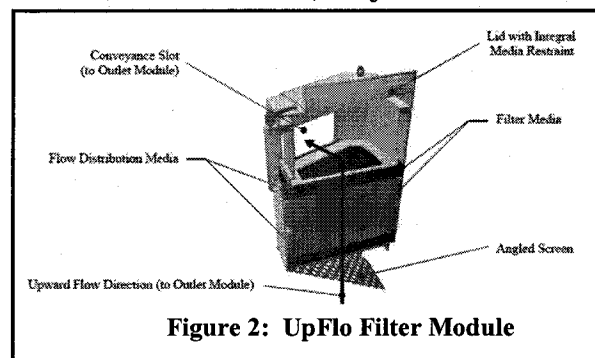

Figure 2: UpFlo Filter Module

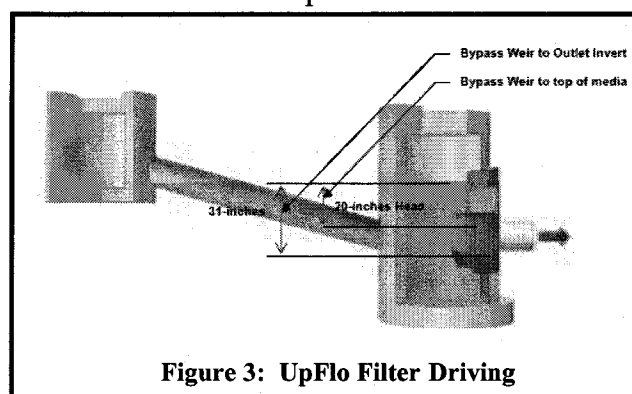

Figure 3: UpFlo Filter Driving

water quality design storm is controlled by upstream detention/attenuation for 12 hours or more, the minimum sediment storage volume does not apply.

6. This conditional certification does not extend to the enhanced removal rates under N.J.A.C. 7:8-5.5 through the addition of settling chambers (such as a hydrodynamic separator) or media filtration practices (such as a sand filter).
7. The maintenance plan for sites using this device shall incorporate, at a minimum, the maintenance requirements in the attached the Upflo-Filter Operation and Maintenance Manual.

In addition to the attached, the detailed maintenance plan must include all of the items identified in Chapter 8: Maintenance of the New Jersey Stormwater Best Management Manual. Such items include, but are not limited to, the list of inspection and maintenance equipment and tools, specific corrective and preventative maintenance tasks, indication of problems in the system, and training of maintenance personnel. Additional operation and maintenance information associated with this manufactured treatment device is available from the vendor to assist in the development of a complete maintenance plan.

The Department anticipates proposing further adjustments to this process through future rulemaking for the Stormwater Management Rules. Additional information regarding the implementation of the Stormwater Management Rules N.J.A.C. 7:8 are available at [www.njstormwater.org](http://www.njstormwater.org). If you have any questions regarding the above information, please contact Ms. Sandra Blick of my office at (609) 633-7021.

Sincerely,



Barry Chalofsky, P.P., Chief  
Bureau of Nonpoint Pollution Control

c: chron file  
Tom Micai, NJDEP  
Mary Beth Brenner, NJDEP  
Rhea Weinberg Brekke, NJCAT

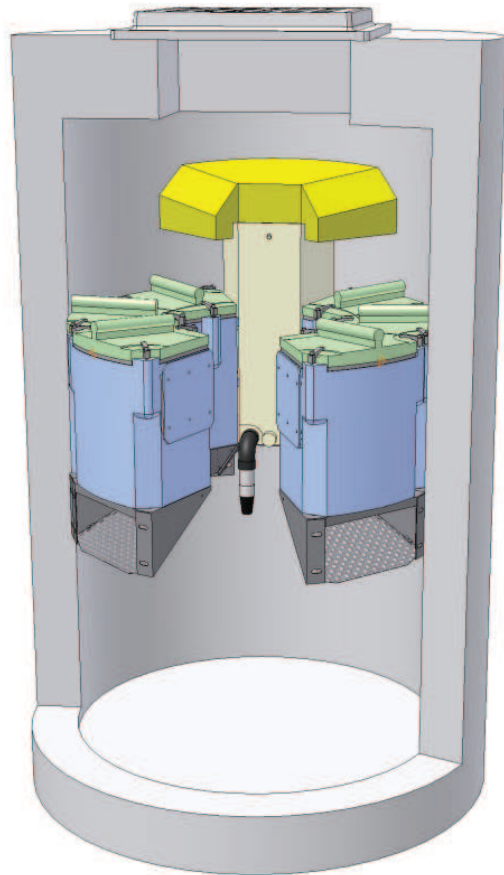

# The Up-Flo<sup>®</sup> Filter

Stormwater Treatment System

## Table of Contents

3	Up-Flo® Filter <ul style="list-style-type: none"><li>- Overview</li><li>- General Product Description</li><li>- Typical Configurations</li><li>- Maintenance Services</li></ul>
4	Operation <ul style="list-style-type: none"><li>- Introduction</li><li>- Pollutant Capture</li><li>- Reduced Clogging</li><li>- Overflow Protection</li></ul>
5	Maintenance <ul style="list-style-type: none"><li>- Overview</li><li>- First-Year Monitoring</li><li>- Inspection</li><li>- Floatables, Oil and Sump Cleanout</li><li>- Replacement of Media Packs and Drain Down Filter</li></ul>
12	Up-Flo® Filter Installation Log
13	Up-Flo® Filter Inspection and Maintenance Log

### **IMPORTANT** - ORDER REPLACEMENT PARTS FOR MAINTENANCE - **IMPORTANT**

Annual maintenance requires replacement of the filter media packs and the Drain Down filter. Contact Hydro International to order replacements. Allow 2-4 weeks for delivery.

Office hours Monday thru Friday 8:00 A.M. to 5:00 P.M. EST  
Toll free: 1-800-848-2706  
Phone: 207-756-6200  
Fax: 207-756-6212  
Email: [hiltech@hil-tech.com](mailto:hiltech@hil-tech.com)

---

**COPYRIGHT STATEMENT:** The contents of this manual, including the drawings and specifications contained herein or annexed hereto, are intended for the use of the recipient to whom the document and all associated information are directed. Hydro International plc owns the copyright of this document (including any drawings or graphics), which is supplied in confidence. It must not be used for any purpose other than that for which it is supplied and must not be reproduced, in whole or in part stored in a retrieval system or transmitted in any form or by any means without prior permission in writing from Hydro International plc. Up-Flo® Filter is a trademarked filtration device of Hydro International plc. A patent covering the Up-Flo® Filter has been granted.

**DISCLAIMER:** Information and data contained in this manual is exclusively for the purpose of assisting in the operation and maintenance of Hydro International plc's Up-Flo® Filter. No warranty is given nor can liability be accepted for use of this information for any other purpose. Hydro International plc have a policy of continuous product development and reserve the right to amend specifications without notice.



## Product Overview

The Up-Flo® Filter is a modular high-rate stormwater filtration device. As shown below, it is typically installed into a 4-ft diameter catch basin structure. Each Filter Module has a screen and support bracket that is attached to the concrete manhole and each contains a Media Pack that includes flow distribution and filtration media. Modules can attach to each other to form a “ring” of up to six modules. Up to two of the modules are attached to an Outlet Module that has a Bypass Hood and filtered Drain Down. The modular design can be supplied in different configurations depending on the application as shown in the following illustrations.

An upward flow path through the Filter Modules allow stormwater to be screened and filtered. In addition to the screening and filtering processes, gross pollutants will also settle into the sump or float to the surface of the water held within the manhole. The standard units are supplied with a 3-ft sump to allow for sediment and gross pollutant accumulations between maintenance intervals.

The following manual describes the operation of the Up-Flo Filter and provides general maintenance requirements that will ensure the filter will continue to operate and perform as intended. In general, a minimum of two inspections are required per year to monitor sediment and gross pollutant accumulations. In order to achieve an annual TSS removal rate of 80% for the Up-Flo

Filter, the minimum maintenance frequency specified in the maintenance section for replacement of the Media Pack and removal of accumulated sediment from the sump is mandatory.

Hydro International offers maintenance contracts nationwide, through Drainage Protections Systems (DPS). It is hoped that owners will take advantage of this service as operators of DPS have been trained and certified to ensure that maintenance will be performed properly. Should the owner choose to conduct maintenance procedures themselves, it is recommended that Hydro International be contacted to discuss the following procedures and consider contracting a representative from Hydro International for the first maintenance cycle.

Contact our Production Department

Office hours Monday thru Friday 8:00 A.M. to 5:00 P.M. EST

Toll free: 1-800-848-2706

Phone: 207-756-6200

Fax: 207-756-6212

### UP-FLO FILTER COMPONENTS

1. Inlet Grate
2. Bypass Siphon with Floatables Baffle
3. Filter Module
4. Outlet Module
5. Media Pack
6. Angled Screen
7. Drain Down Assembly (not visible)
8. Sump

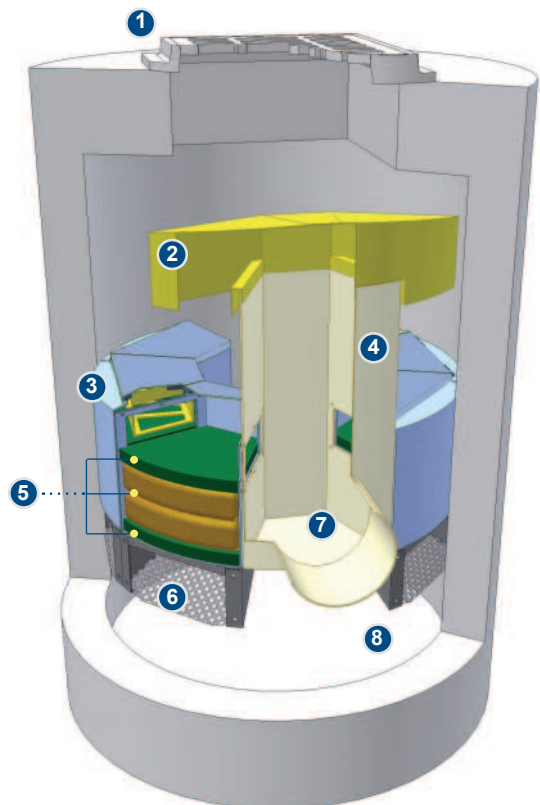

## Configurations

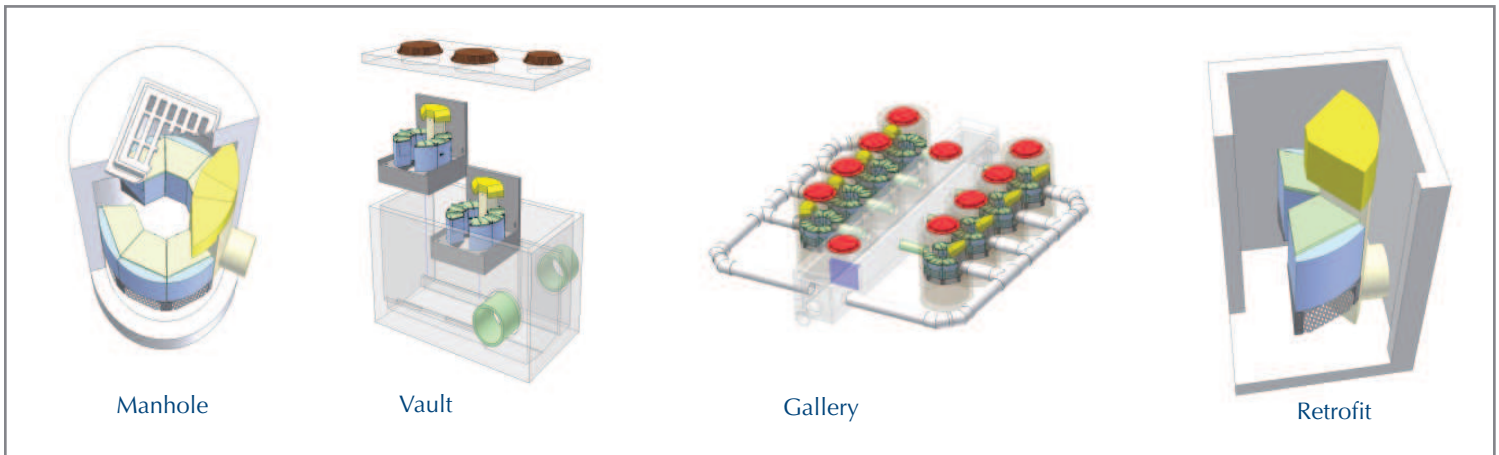

## Operation

### INTRODUCTION

The Up-Flo Filter operates on simple fluid hydraulics. It is self-activating, has no moving parts, no external power requirements and is fabricated with durable non-corrosive components. Personnel is not required to operate the unit and maintenance is limited to periodic inspections, sediment and floatables removal, Media Pack replacement and Drain Down Filter replacement.

### POLLUTANT CAPTURE

The Up-Flo Filter is designed to operate as a “treatment train” by incorporating multiple treatment technologies into a single device. Trash and gross debris are removed by sedimentation and screening before they are introduced to the filtration media, preventing surface blinding of the filter media. The Up-Flo Filter is a wet-sump device. Between storm events, oil and floatables are stored on the water surface separate from the sediment storage volume in the sump (see Figure 1). The high-capacity bypass siphon acts as a floatables baffle to prevent washout of captured floatable pollutants during high-intensity events.

### REDUCED CLOGGING

The Up-Flo Filter has been designed to minimize the occurrence of clogging and blinding. The Up-Flo Filter employs a unique Drain Down design that allows the water level in the chamber to drop below the filter media between events. The Drain Down mechanism creates a reverse flow that flushes captured pollutants off the surface of the filter bag, helping to prevent blinding. By allowing the water to drain out, the drain-down mechanism also reduces the weight of the filter bags. This makes the bags easier and safer to remove during maintenance operations.

### OVERFLOW PROTECTION

The Angled Screens are designed to prevent ragging and blinding. The Angled Screens are situated below the Filter Modules, sheltering them from the direct path of the influent. Coarse debris settles in the sump before the runoff flows up through the screens, protecting them from blinding. In the unlikely event of a blockage, the high capacity Siphonic Bypass is designed to convey high enough flow that large storm events will not create upstream flooding.

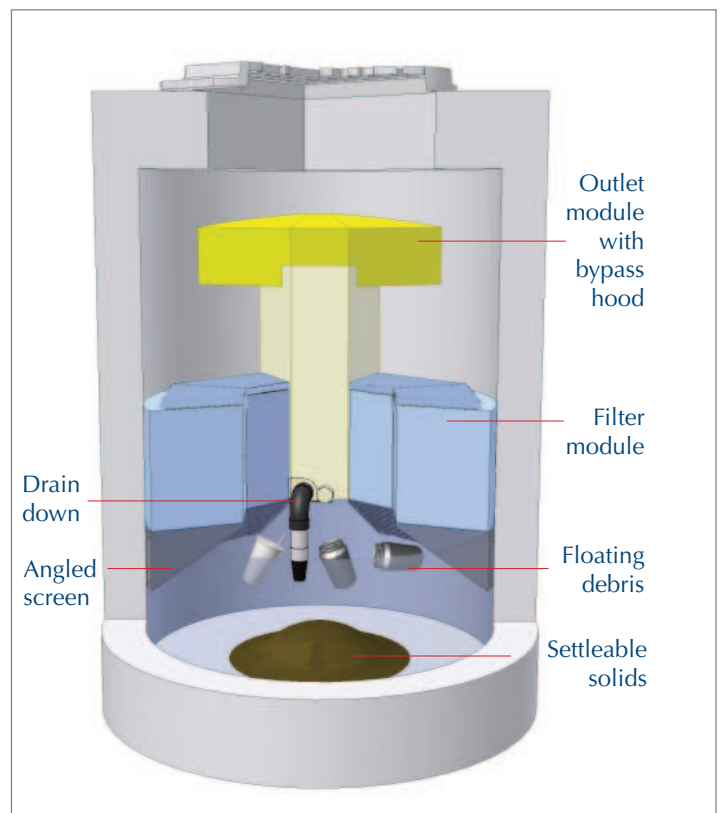

**Figure 1:** Pollutants captured in the Up-Flo Filter



## Maintenance

### OVERVIEW

The Up-Flo Filter protects the environment by removing a wide range of pollutants from stormwater runoff. Periodic removal of these captured pollutants is essential to the proper functioning of the Up-Flo Filter. Media Packs should not be installed in the modules until construction activities are complete and site stabilization is effective.

The Up-Flo Filter design allows for easy and safe inspection, monitoring and clean-out procedures. It has a wide central opening between the Filter Modules for easy and comfortable access to all of the components (See figure 2). Completion of all the maintenance activities for a typical manhole Up-Flo Filter takes less than one hour. In the case of inspection and floatables removal, a vactor truck is not required. Otherwise, a vactor truck is normally required for oil removal, removal of sediment from the sump, and replacement of the Media Packs and Drain Down Filter. In most cases, entry into the Up-Flo Filter vessel is required for replacement of the Media Packs and Drain Down Filter, and OSHA Confined Space Entry procedures will have to be followed.

Maintenance activities include inspection, floatables removal, oil removal, sediment removal, Media Pack replacement, and Drain Down Filter replacement. The minimum required frequency for replacement of the Media Pack is annually, whereas the minimum required frequency for removal of accumulated sediment from the sump is dependent on the Up-Flo Filter configuration. Configurations with a larger sediment storage volume per module will require less frequent removal of accumulated sediment. Regardless, whenever sediment depth in the sump is found to be greater than 8 inches, sediment removal is required.

### MONITORING FOR POLLUTANT ACCUMULATION

During inspections, the following methods should be used to check for pollutant accumulation:

- **Floatables and Oil Monitoring:** The water surface in the Up-Flo Filter should be monitored for accumulation of floatables and oil. Floatables should not be allowed to accumulate to the point where they completely cover the surface of the water. Oil should not be allowed to accumulate to the point where it has formed a measurable thickness on the surface of the water. The rate of floatables and oil accumulation can be estimated by dividing the surface area covered by floatables and/or oil by the number of months since the Up-Flo Filter was last maintained.

- **Sediment Monitoring:** A simple probe, such as the Sludge-Judge®, should be used to determine the depth of sediment in the

sump. The maximum allowable sediment depth in any Up-Flo Filter configuration is 8". The rate of sediment accumulation can be estimated by dividing the measured depth of sediment by the number of months since the Up-Flo Filter was last maintained.

- **Media Pack Monitoring:** Each Up-Flo Filter will be equipped with a high-water level indicator designed to activate when the water level inside the structure reaches the bypass weir elevation. The indicator is comprised of a pipe stub fastened in a vertical orientation to the outlet module and a bright-colored buoyant ball set loosely in the pipe stub. The indicator is set at an elevation such that the ball floats out of the pipe when the water level reaches the bypass weir elevation. If the ball cannot be seen in the pipe by maintenance personnel looking into the structure from ground level, then the ball has floated free, indicating that the Up-Flo Filter may have gone into bypass. Maintenance personnel should place the ball back into the pipe in order to reset the indicator. If the indicator has been activated after two consecutive storms, it is an indication that the filter bags may have exceeded their capacity for filtered solids and that the filtered media may have become clogged. Maintenance personnel should then enter the structure, remove the Media Pack from one of the Filter Modules, and weigh the filter bags. Filter bags with a wet weight of approximately 40 lbs (or more) are a final indication that the filter media has become clogged and that the Media Packs in all of the Filter Modules will require replacement.

- **Drain Down Filter Monitoring:** The water level in the Up-Flo Filter should be monitored to ensure that the Drain Down Filter is operating properly. Approximately 36 hours after a one-inch rainfall, the water level inside the vessel should have dropped to a point where it is equal with the base of the Filter Modules. If the water level has not reached that point, then the Drain Down Filter has either become clogged or blinded by trash or debris. If there is no evidence of trash or debris around the Drain Down Filter inlet, then it has likely become clogged with particles.

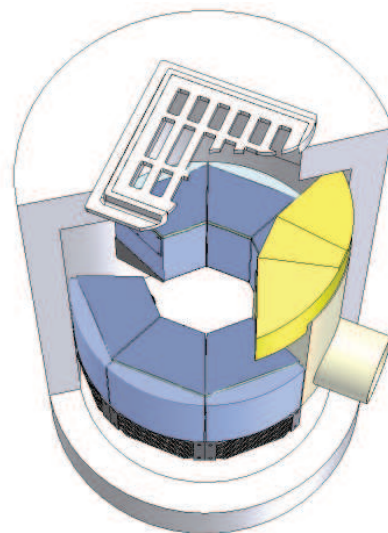

**Figure 2:** The wide central opening in the Up-Flo Filter



## INSPECTION

Inspection is a simple process that requires monitoring pollutant accumulations. Maintenance crews should be familiar with the Up-Flo Filter and its components prior to inspection.

### SCHEDULING

- Inspection may be conducted during any season of the year but should occur shortly after a predicted rainfall to ensure components are operating properly.

### RECOMMENDED EQUIPMENT

- Safety Equipment and Personal Protective Equipment (traffic cones, work gloves, etc.)
- Scale to measure the weight of the filter bags
- Crow bar to remove grate or lid
- Pole with skimmer or net
- Sediment probe (such as a Sludge Judge)
- Hydro International Up-Flo Filter Maintenance Log
- Trash bags for removed floatables

1. Set up any necessary safety equipment (such as traffic cones) to provide access to the Up-Flo Filter. Safety equipment should notify passing pedestrian and road traffic that work is being done.
2. Remove the grate or lid to the manhole or vault.
3. Without entering the vessel, look down into the chamber to inspect the inside and to determine whether the high-water level indicator has been activated. Make note of any irregularities. See Figure 3 for a typical Inspection View.
4. Without entering the vessel, use the pole with the skimmer net to remove floatables and loose debris from the chamber.
5. Using a sediment probe such as a Sludge Judge, measure the depth of sediment that has collected in the sump of the vessel. Maximum sediment depth is 8 inches.
6. If the high-water level indicator has been activated after two-consecutive storms, remove the Filter Module lid by turning the cam latch and remove the Filter Media Pack (*refer to page 8 Replacement Procedures*). Weigh the filter bags from one or two modules. Filter bags should be replaced if the wet weight exceeds 40 lbs.
7. On the Maintenance Log provided by Hydro International, record the date, unit location, estimated volume of floatables and gross debris removed, and the depth of sediment measured. Also note any apparent irregularities such as damaged components or a high standing water level (see Figure 3 for the standard standing water level).
8. Securely replace the grate or lid.
9. Remove safety equipment.
10. Contact Hydro International at 1-800-848-2706 to discuss any irregularities noted during inspection.

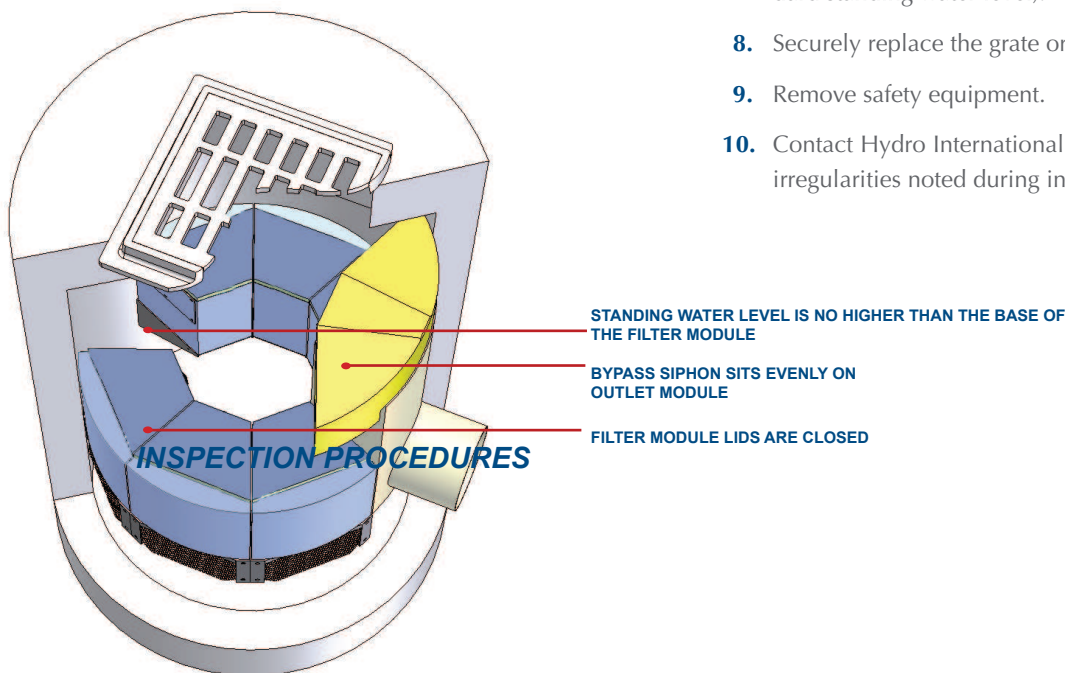

Figure 3: Inspection view of the Up-Flo Filter

## FLOATABLES, OIL, AND SUMP CLEANOUT

A commercially or municipally owned sump-vac is used to remove captured sediment, oil and floatables (Figure 4).

Floatables and loose debris can also be netted with a skimmer and pole. The access port located at the top of the manhole provides unobstructed access for a vactor hose and skimmer pole to be lowered to the base of the sump.

### SCHEDULING

- Floatables and sump cleanout may typically be done during any season of the year - before and after rainy season
- Floatables and sump cleanout should occur as soon as possible following a contaminated spill in the contributing drainage area

### RECOMMENDED EQUIPMENT

- Safety Equipment (traffic cones, etc)
- Crow bar to remove grate or lid
- Pole with skimmer or net (if only floatables are being removed)
- Sediment probe (such as a Sludge Judge)
- Vactor truck (flexible hose preferred)
- Pressure nozzle attachment or other screen-cleaning device
- Hydro International Up-Flo Filter Maintenance Log

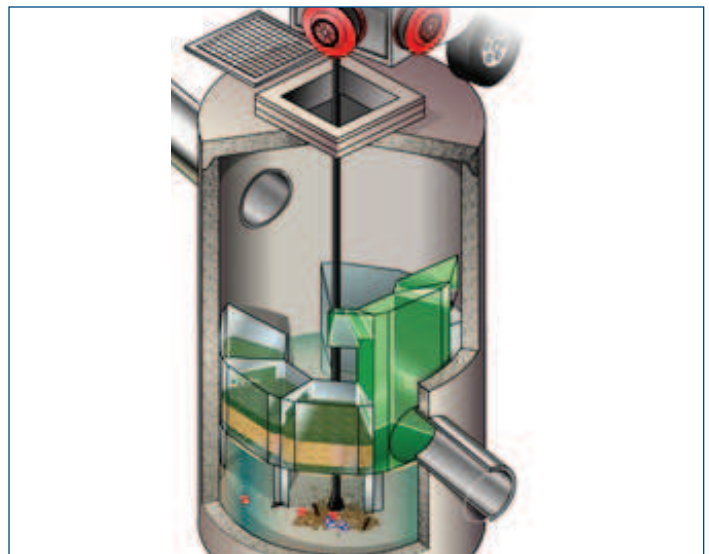

**Figure 4:** Sediment is removed with a vactor hose

**FLOATABLES, OIL AND SUMP CLEAN OUT PROCEDURES**

1. Set up any necessary safety equipment (such as traffic cones) around the access of the Up-Flo Filter. Safety equipment should notify passing pedestrian and road traffic that work is being done.
2. Remove the grate or lid to the manhole or vault.
3. Without entering the vessel, look down into the chamber to inspect the inside. Make note of any irregularities.
4. If the standing water level in the sump is above the base of the Filter Modules (see Figure 3), tug the Pull Chain(s) to release the Drain Down Plug(s). Allow the excess water to drain out of the chamber.
5. Use the skimmer pole to fit the Drain Down plug back into the open port.
6. Once all floatables and oil have been removed, drop the vacator hose to the base of the sump. Vactor out the sediment and gross debris from the sump floor. Up to 0.3 yd<sup>3</sup> of sediment and 360 gallons of water will be removed from a typical manhole Up-Flo Filter during this process.
7. Retract the vacator hose from the vessel.
8. Inspect the Angled Screens for blockages and ragging. If present, remove the obstruction or ragging materials from the surface using a hose or other screen-cleaning device.
9. On the Maintenance Log provided by Hydro International, record the date, unit location, estimated volume of floatables, oils, and gross debris removed, and the depth of sediment measured. Note any apparent irregularities such as damaged components or blockages.
10. Securely replace the grate or lid.
11. Remove safety equipment.
12. Dispose of sediment and gross debris at your local landfill; following local regulations.
13. Dispose of oil and sump water at a licensed water treatment facility.
14. Contact Hydro International at 1-800-848-2706 to discuss any irregularities noted during cleanout.

**REPLACEMENT OF MEDIA PACKS AND DRAIN DOWN FILTER**

Unless the Up-Flo Filter has been installed as a very shallow unit, it is necessary to have an OSHA-confined space entry trained person enter the vessel to replace Media Packs.

**SCHEDULING**

- Call Hydro International to order replacement Media Packs and Drain Down filter prior to scheduling maintenance.
- Because Media Pack replacement requires entry into the Up-Flo chamber, maintenance events should be scheduled during dry weather.
- Media Pack replacement should occur immediately after a contaminated spill in the contributing drainage area.

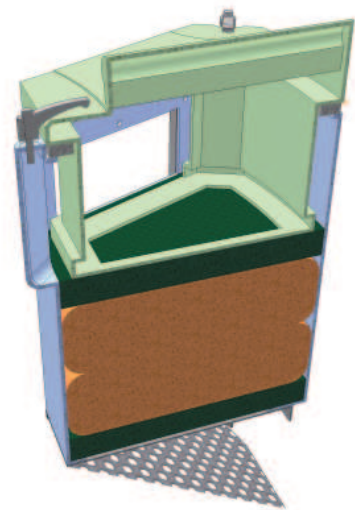

**Figure 5:** Cut-away view of the Filter Module

**RECOMMENDED EQUIPMENT**

- Safety Equipment (traffic cones, etc.)
- Crow bar to remove grate or lid
- Pole with skimmer or net (if floatables removal is not to be done with vactor hose)
- Sediment probe (such as a Sludge Judge)
- Vactor truck (flexible hose preferred)
- OSHA Confined Space Entry Equipment
- Up-Flo Filter Replacement Media Packs (available from Hydro International)
- Hydro International Up-Flo Filter Maintenance Log
- Screwdriver (flat head)
- Replacement Drain Down Filter components supplied by Hydro International

**MEDIA PACK AND DRAIN DOWN FILTER REPLACEMENT PROCEDURES**

1. Follow Floatables and Sump Cleanout Procedures, 1 – 10.
2. Following OSHA Confined Space Entry procedures, enter the Up-Flo Filter Chamber.
3. Open the Filter Module by turning the three cam latches on the front and sides of the module. Remove the lid ❶ to gain access to the Media Pack (Figure 6).
4. Remove and discard the spent **Media Pack**. The **Media Pack** contents include:
  - A top layer of green ❷ Flow-Distributing Media.
  - Two (2) Media Bags ❸ equipped with nylon handles.
  - A bottom layer of green ❷ Flow-Distributing Media.

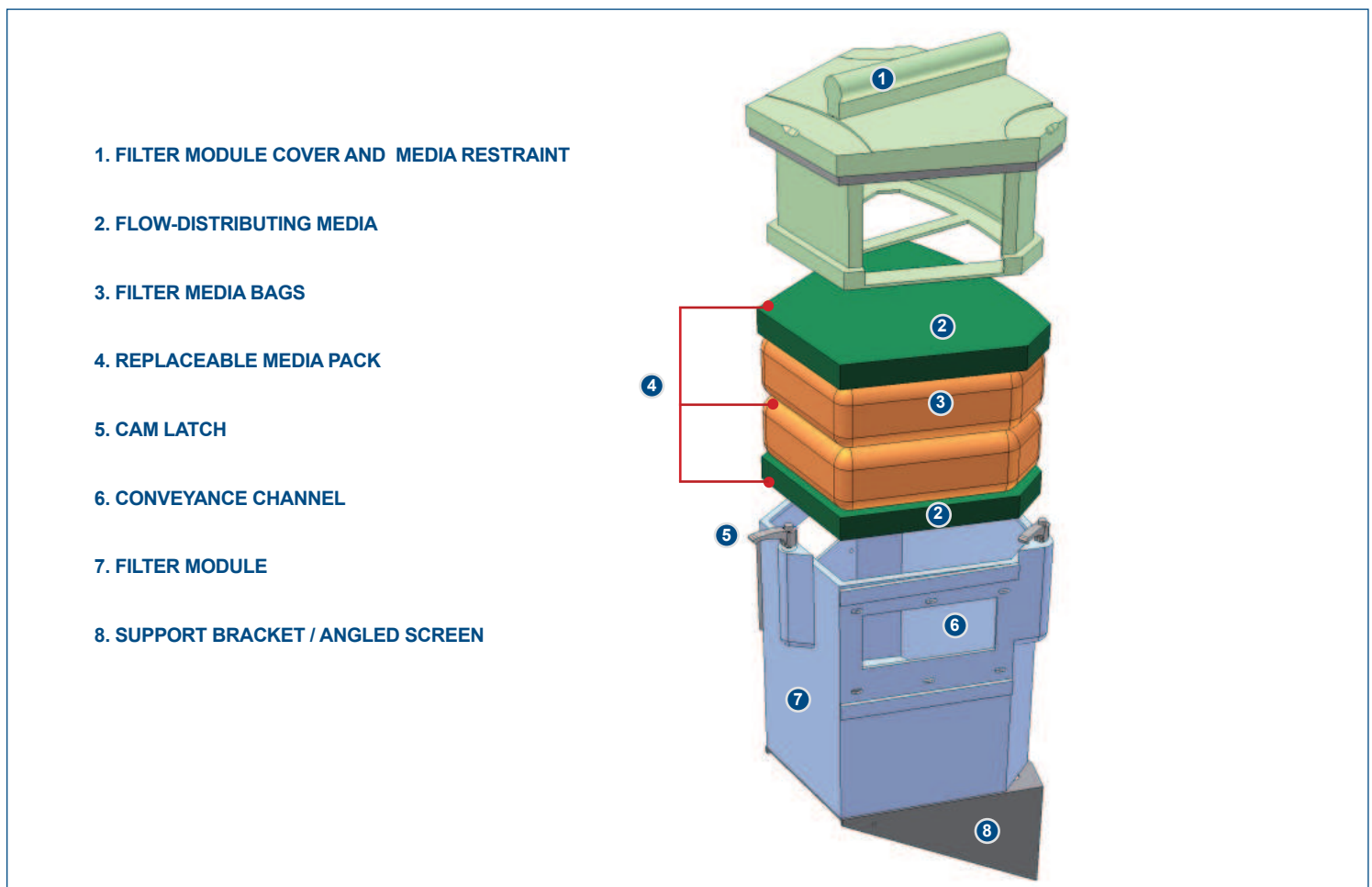

**Figure 6:** The Filter Module houses the Media Restraint and the Media Pack

5. Insert a new Media Pack, supplied by Hydro International.
  - First, insert a bottom layer of green **Flow-Distributing Media**. Be sure that the media sits snugly and level at the bottom of the Filter Module.
  - Next, insert the first of two (2) replacement **Media Bags**. Smooth the bag out with your hands to make sure that the bag extends snugly to the walls and corners of the Filter Module.
  - Insert the second **Media Bag**, following the same procedure.
  - Insert the top layer of green **Flow-Distributing Media**. Be sure that the piece fits snugly against the walls and corners of the Filter Module.
  - Put the lid on and secure the three latches. Check to make sure that the latches are closed properly.
6. Use a screwdriver to unscrew the **Drain Down Filter** from the face of the Outlet Module (see Figure 7). **DO NOT DISCARD THIS PIECE.**
7. Install new **Drain Down Filter** supplied by Hydro International.
8. Exit the Up-Flo Filter chamber and securely replace the grate or lid.

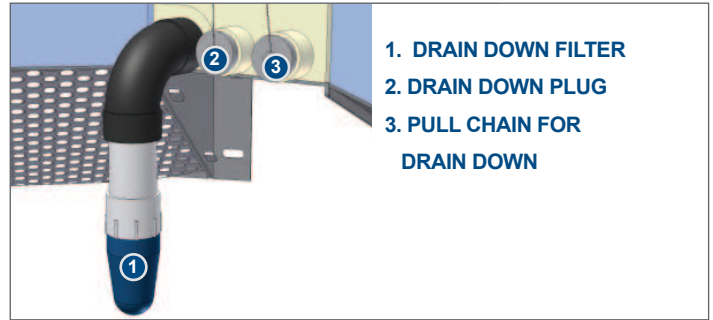

Figure 7: The Drain Down Filter

9. On the Maintenance Log provided by Hydro International, record the date, unit location, estimated volume of floatables, oil and gross debris removed, and the depth of sediment measured. Note the number of Media Packs replaced. Note any irregularities such as damaged components or blockages.
10. Remove safety equipment.
11. Dispose of spent media packs at your local landfill, following local regulations.
12. Return the spent Drain Down Filter to Hydro International.
13. Contact Hydro International to discuss any irregularities noted during annual maintenance.

## Maintenance at a Glance

ACTIVITY	FREQUENCY
Inspection	- Regularly during first year of installation - Every 6 months after the first year of installation
Floatables/Oils Removal	- Twice per year or as needed - Following a contaminated spill in the drainage area
Sediment Removal	- Every six to 12 months, depending on the Up-Flo® Filter Configuration - The maximum allowable sediment depth in any Up-Flo Filter configuration is 8" - Following a contaminated spill in the drainage area
Media Pack Replacement	- Once per year - Replacement is required anytime inspection reveals that the high-water level indicator has been activated after two consecutive storms and the subsequent weighing of the filter bags shows a wet weight greater than 40 lbs - Following a contaminated spill in the drainage area
Drain Down Filter Replacement	- Once per year with Media Pack replacement - Replacement is required anytime inspection reveals that the water level inside the vessel has not reached a level equal with the base of the Filter Modules approximately 36 hours after a 1-inch rainfall - As needed, in the event of continuous base flow conditions

# UP-FLO® FILTER

## INSPECTION & MAINTENANCE LOG

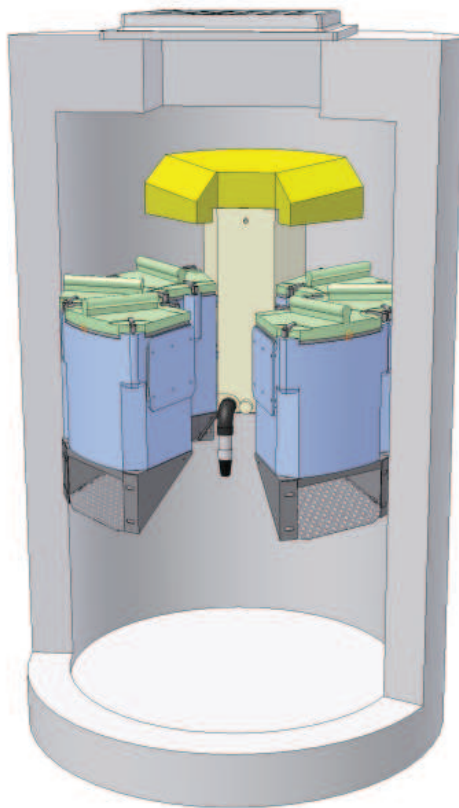



## Up-Flo® Filter Installation Log

HYDRO INTERNATIONAL REFERENCE NUMBER:	
SITE NAME:	
SITE LOCATION:	
OWNER:	CONTRACTOR:
CONTACT NAME:	CONTACT NAME:
COMPANY NAME:	COMPANY NAME:
ADDRESS:	ADDRESS:
TELEPHONE:	TELEPHONE:
FAX:	FAX:

INSTALLATION DATE:    /    /

CONFIGURATION (CIRCLE ONE):      MANHOLE      VAULT SYSTEM      GALLERY      RETROFIT

TOTAL NUMBER OF UP-FLO FILTER MODULES: \_\_\_\_\_







[www.hydro-international.biz](http://www.hydro-international.biz)

#### United Kingdom

Shearwater House • Clevedon Hall Estate  
Victoria Road • Clevedon, BS21 7RD  
Tel: +44 (0) 1275 878371  
Fax: +44 (0) 1275 874979

#### United States

94 Hutchins Drive  
Portland, ME 04102  
Tel: 207 756 6200  
Fax: 207 756 6212

#### Ireland

Tootenhill House  
Rathcoole • Co Dublin  
Tel: +353 (0)1 4013964  
Fax: +353 (0)1 4013978

